SMIQ as Fading Simulator for External Signals

Application Note 1MA07_0E

Subject to change
Roland Minihold 98-3

Products:

Signal Generator SMIQ
Signal Generator SMT/SME



ROHDE & SCHWARZ

Contents

1. Overview
2. Problem Definition
3. Principle of SMIQ Signal Processing with Vector Modulation
4. Suggested Measurement Procedures
 - 4.1. Signal Supplied by Signal Generator
 - 4.2. Suppression of Unwanted Sideband with 90° Power Splitter
 - 4.3. Use of Additional Mixer and 90° Phase Shifter
 - 4.4. Use of External IQ Demodulator
5. Summary of Pros and Cons
6. References
7. Ordering Information

1. Overview

Signal Generator SMIQ has versatile analog and digital internal modulation capabilities. Optional Fading Simulator SMIQ-B14 adds a variety of fading functions to the integrated digital modulation capabilities of SMIQ at a highly attractive price as compared with similar products. This application note describes how to apply fading to signals of any source and with any type of modulation (analog and digital) in a very convenient way.

2. Problem Definition

Multipath reception (fading) causes problems in the receiver sections of both analog and digital radio-communication systems. To test receiver sensitivity with regard to fading, very expensive fading simulators have been required so far. SMIQ fitted with option SMIQ-B14 offers versatile fading capabilities for the integrated digital modulation functions at a favourable price. In the following, various ways are described of how to expand the fading capabilities of SMIQ as required for a given application using additional equipment. Thus, signals of any source and with any type of modulation can be faded, for example analog FM- or PM-modulated mobile radio signals, FM stereo sound broadcast signals, VOR/ILS signals, digitally modulated pager signals to POCSAG, ERMES, FLEX or REFLEX standard.

3. Principle of SMIQ Signal Processing with Vector Modulation

Fig. 1 is a basic diagram showing the location of the fading simulator in SMIQ.

The fading simulator operates in the baseband and can be used both with signals generated by the modulation coder and with external IQ signals. It has a 3 dB bandwidth of 7 MHz; the roll-off is <0.5 dB up to 5 MHz.

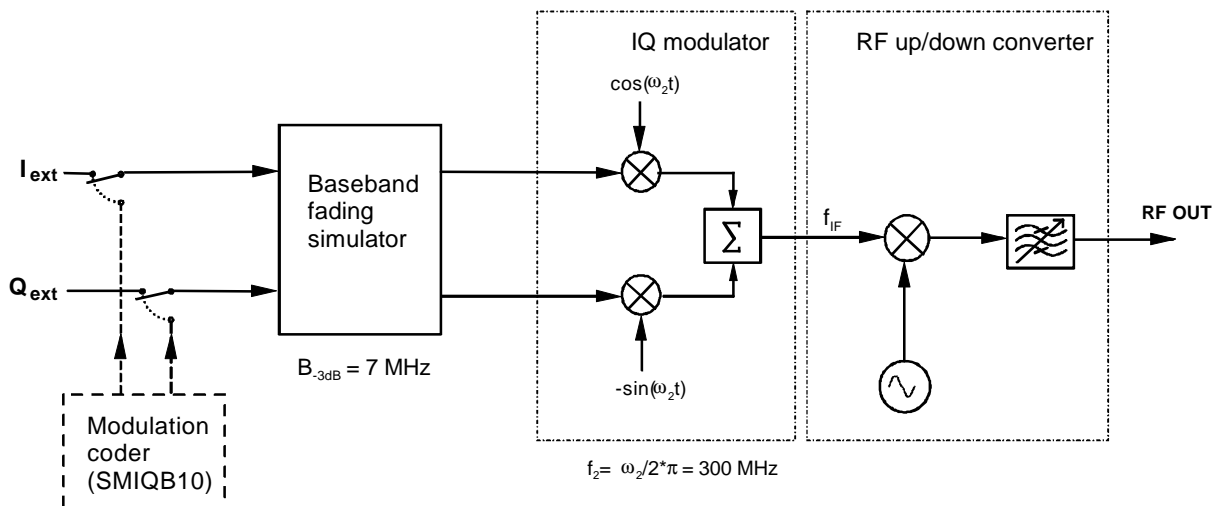

Fig. 1: Basic diagram showing signal processing with vector modulation and fading simulation in SMIQ

The output signals of the fading simulator are taken to the IQ modulator, which operates at an IF of 300 MHz. The IF is converted to the output frequency by means of an up/downconverter.

External signals (I, Q) can be applied to the fading simulator basically in the following ways:

1. The I and Q components of the signal to be faded are available in the baseband.
2. A modulated carrier signal is applied to the I or Q input.
3. A modulated carrier signal is applied to the I input and simultaneously, phase-shifted by 90°, to the Q input.

The different techniques of applying the signal:

1. I/Q signals in baseband:

The I and Q signals are available in the baseband (for example from Arbitrary Waveform Generator **ADS** from Rohde & Schwarz). This corresponds to signal feed from the internal modulation coder.

The IF frequency of the IQ modulator is in this case equal to its LO frequency of $f_2 = 300$ MHz.

The output frequency of SMIQ is equal to the set frequency.

2. Modulated carrier signal to either I or Q input:

A modulated carrier signal with the frequency f_1 is applied to one of inputs I or Q. The signal is converted in the IQ modulator same as in a normal mixer.

Let the signal at the I input of SMIQ be:

$$A_1(t) = A(t) * \cos(w_1 * t + y(t)),$$

where

$A(t)$ is the time function of the amplitude

$$w_1 = 2\pi * f_1$$

and $y(t)$ is the time function of the phase

(with no signal present at Q input).

The signal is multiplied with the LO signal of the IQ modulator in the upper mixer.

The output signal of the IQ mixer is as follows:

$$\sum A(t) = A(t) * \cos(w_2 * t + j) * \cos(w_1 * t + y(t))$$

Using the trigonometric function

$$\cos a * \cos b = \frac{1}{2} * \cos(a - b) + \frac{1}{2} * \cos(a + b)$$

the following is obtained:

$$\begin{aligned} \sum A(t) &= \frac{1}{2} * A(t) * \cos(w_2 * t + j - w_1 * t - y(t)) \\ &\quad + \frac{1}{2} * A(t) * \cos(w_2 * t + j + w_1 * t + y(t)) \\ &= \frac{1}{2} * A(t) * \cos((w_2 - w_1) * t + j - y(t)) \\ &\quad + \frac{1}{2} * A(t) * \cos((w_2 + w_1) * t + j + y(t)) \end{aligned}$$

In this way, two signals with a sum and a difference frequency (f_2+f_1, f_2-f_1), each with the amplitude 1/2, are obtained at the output of the IQ modulator, formed by the applied carrier frequency and the LO frequency.

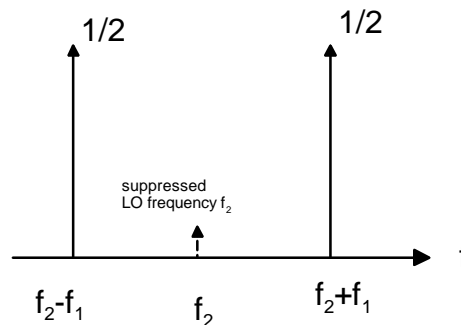

Fig. 2: Output spectrum of IQ modulator with carrier signal f_1 applied to I input

3. Modulated carrier signal to I input and simultaneously, phase-shifted by 90°, to Q input

The Q signal is identical to the I signal except for a phase shift of 90°.

In this case, single-sideband frequency conversion takes place in the IQ modulator of SMIQ. The output frequency is as follows:

Frequency set on SMIQ + carrier frequency f_1 (or - carrier frequency f_1 , depending on whether the I or the Q signal is leading in phase). The other sideband and the frequency set on SMIQ are suppressed. The degree of suppression depends on the quality of the I/Q modulator, the accuracy of the 90° phase shift and the I and Q amplitude imbalance.

The basic function can be deduced easily as follows:

Let the signal at the I input of the IQ modulator be:

$$A_1(t) = A(t) * \cos(\omega_1 * t + y(t))$$

The signal at the Q input is identical but shifted by +90° in phase. This corresponds to a sinewave signal, ie:

$$A_2(t) = A(t) * \sin(\omega_1 * t + y(t))$$

In the IQ modulator of SMIQ, $A_1(t)$ and $A_2(t)$ are multiplied with the LO signal or the LO signal shifted 90° in phase, respectively, and added. The output signal of the IQ mixer is then as follows:

$$\begin{aligned} \sum A(t) &= A(t) * \cos(\omega_2 * t + \mathbf{j}) * \cos(\omega_1 * t + y(t)) \\ &\quad - A(t) * \sin(\omega_2 * t + \mathbf{j}) * \sin(\omega_1 * t + y(t)) \end{aligned}$$

Using the trigonometric functions

$$\cos \mathbf{a} * \cos \mathbf{b} = \frac{1}{2} * \cos(\mathbf{a} - \mathbf{b}) + \frac{1}{2} * \cos(\mathbf{a} + \mathbf{b})$$

and

$$\sin \mathbf{a} * \sin \mathbf{b} = \frac{1}{2} * \cos(\mathbf{a} - \mathbf{b}) - \frac{1}{2} * \cos(\mathbf{a} + \mathbf{b})$$

the following is obtained:

$$\begin{aligned} \sum A(t) &= \frac{1}{2} * A(t) * \cos(\omega_2 * t + \mathbf{j} - \omega_1 * t - y(t)) \\ &\quad + \frac{1}{2} * A(t) * \cos(\omega_2 * t + \mathbf{j} + \omega_1 * t + y(t)) \\ &\quad - \frac{1}{2} * A(t) * \cos(\omega_2 * t + \mathbf{j} - \omega_1 * t - y(t)) \\ &\quad + \frac{1}{2} * A(t) * \cos(\omega_2 * t + \mathbf{j} + \omega_1 * t + y(t)) \end{aligned}$$

The terms with

$$\frac{1}{2} * A(t) * \cos(\omega_2 * t + \mathbf{j} - \omega_1 * t - y(t))$$

cancel one another out to yield the following:

$$\begin{aligned} \sum A(t) &= A(t) * \cos(\omega_2 * t + \mathbf{j} + \omega_1 * t + y(t)) \\ &= A(t) * \cos((\omega_2 + \omega_1) * t + \mathbf{j} + y(t)) \end{aligned}$$

In this case, only a signal with the sum frequency (applied carrier frequency f_1 + LO frequency f_2 of IQ modulator) is obtained at the output of the IQ modulator; the modulation (time-dependent amplitude $A(t)$ and phase $\psi(t)$) is maintained.

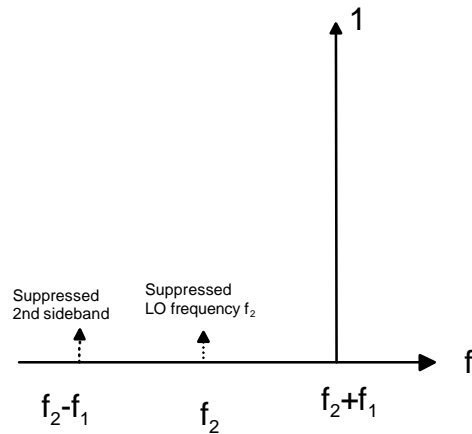

Fig. 3: Output spectrum of IQ modulator with carrier signal applied to I input and, with 90° phase shift, to Q input

The output frequency of SMIQ is then as follows: frequency set on SMIQ + applied carrier frequency.

4. Suggested Measurement Procedures

To furnish signals with analog modulation, Signal Generator SMT from R&S is particularly suitable, whereas SME is an ideal source for special digitally modulated signals (and analog signals in addition). SME features as standard the ERMES protocol, for example, and the following protocols are optionally available:

FLEX protocol: SME-B41
POCSAC protocol: SME-B42
REFLEX TM protocol: SME-B43

Setting of SMIQ fading simulator:

The setting of the SMIQ fading simulator greatly depends on requirements. Setting parameters include type of fading (eg Rayleigh fading), simulated speed, delay between fading channels, and number of fading channels.

SMIQ output power with fading:

If fading is activated, the maximum possible output level of SMIQ is reduced by 18 dB, ie the "Level overrange" warning will be output already on exceeding a set level of -5 dBm.

For further information please refer to section 2.9.1 of SMIQ operating manual.

Level at IQ inputs of SMIQ:

The rated peak voltage at the IQ inputs is 0.5 V. This corresponds to a level of +7 dBm in the case of modulation with constant amplitude (eg FSK, MSK). For modulation types with varying amplitude (eg AM, PSK, QAM), the level must be reduced accordingly (eg by -6 dB with AM) since it must be ensured in these cases too that the peak voltage of 0.5 V at the IQ inputs is not exceeded. The output level of SMIQ is reduced correspondingly.

4.1. Signal Supplied by Signal Generator

The easiest and in most cases satisfactory approach

is to generate a signal with any type of modulation at around 3 MHz for f_1 by means of a signal generator (eg SMT or SME). The signal is applied to the I or Q input of Vector Signal Generator SMIQ and upconverted to the desired RF. If the I input is used, the frequency of SMIQ is to be set below the desired output frequency by the amount f_1 (if SMIQ is set above the desired output frequency by f_1 , sideband inversion will result, ie an increase in frequency at the I input will lead to a decrease of frequency of the output signal). The level is to be set for 0.5 V peak voltage (+4 dBm in the case of modulation with constant signal amplitude, and correspondingly less in the case of AM, PSK or QAM).

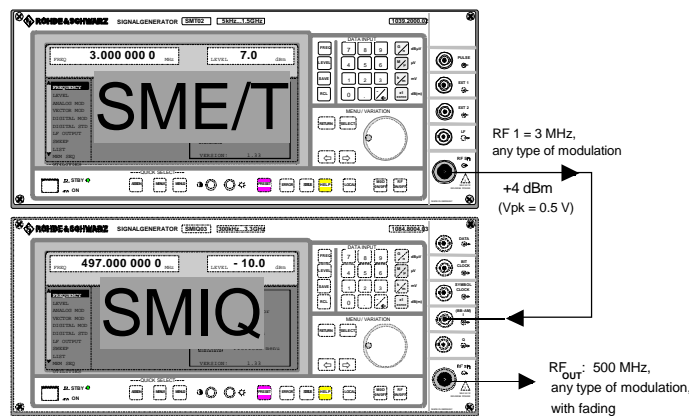

Fig. 4: Generation of faded signal with any type of modulation solely by means of additional signal generator

Settings for generation of faded signal with 500 MHz carrier frequency and any type of modulation:

- SMIQ: Frequency: 497 MHz
 Level: any (max. -5 dBm, ie output level max. -11 dBm because power is split between the two sidebands)
 Vector modulation: ON
 Fading simulator: ON
 Configuration of fading simulator as required for task in hand
- SME/T: Frequency: 3 MHz
 Level +4 dBm¹⁾
 Modulation: any

Output spectrum (see Fig. 5):

Apart from the desired output frequency ①, there appear the suppressed RF (frequency set on SMIQ) and the 2nd sideband (frequency set on SMIQ - f_1). Further spectral components obtained are spurious resulting from the harmonics of the signal applied.

The level of the desired output frequency (and the level of the 2nd sideband) is 6 dB lower than the level set on SMIQ due to the signal power being split up between the two sidebands. This applies to modulation with constant envelope (eg FM, FSK) and a nominal level of +4 dBm at the I/Q inputs.

¹⁾ With AM, PSK or QAM modulation, the level is to be reduced so that the peak voltage at the I (or Q) input will not exceed 0.5 V. For example, with 100% AM, the level must be reduced by 6 dB, ie to -2 dBm.

The additional spectral components should typically have no effect in testing selective receivers. If necessary, the frequency spacing can be slightly

varied by varying the frequency f_1 . However, it must be ensured that f_1 will not exceed 5 MHz (= 0.5 dB bandwidth of fading simulator).

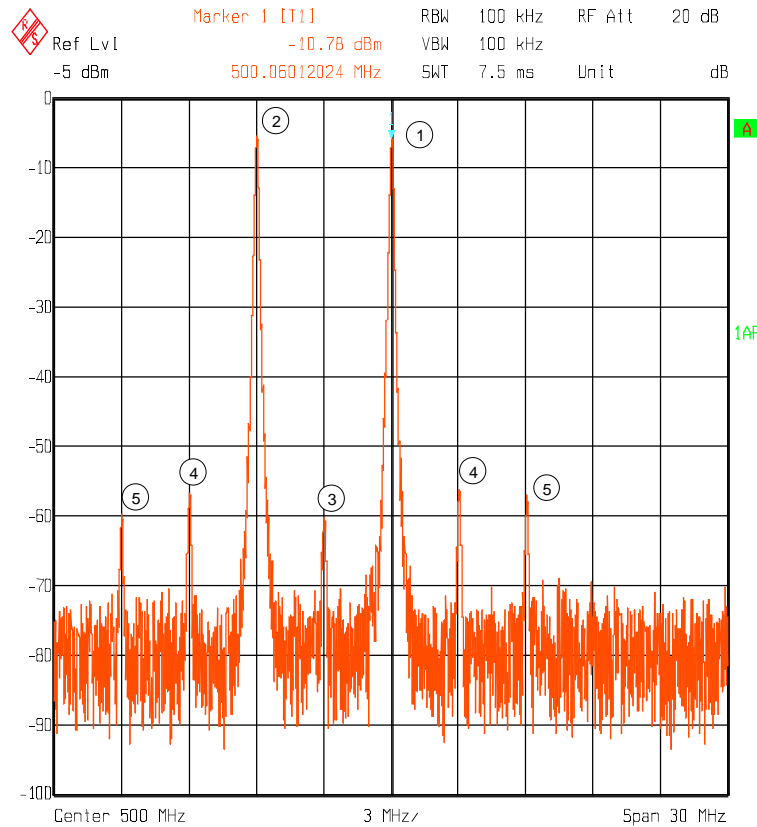

Fig. 5: Output spectrum of SMIQ. At 6 MHz below the useful signal ①, there appears the 2nd sideband at the same level. Both levels are 6 dB lower than the level set on SMIQ.

Evaluation:

- ☺ Simplest test setup
- ☹ The 2nd sideband is not suppressed, the max. output level is reduced by 6 dB as compared with other solutions, and the frequency of the test signal is fixed (approx. 2 to 5 MHz).

4.2. Suppression of Unwanted Sideband with 90° Power Splitter

If it is necessary to suppress the second sideband, it is expedient to use a 90° power splitter that operates in the frequency range 2 to 5 MHz (eg PSCQ-2-8 from Mini Circuits).

Since the Q signal is phase-shifted by 90° relative to the I signal but is otherwise equal, the second sideband is suppressed and the power fully applied to the other sideband. The output level of SMIQ is therefore equal to the set level. The test setup is as follows:

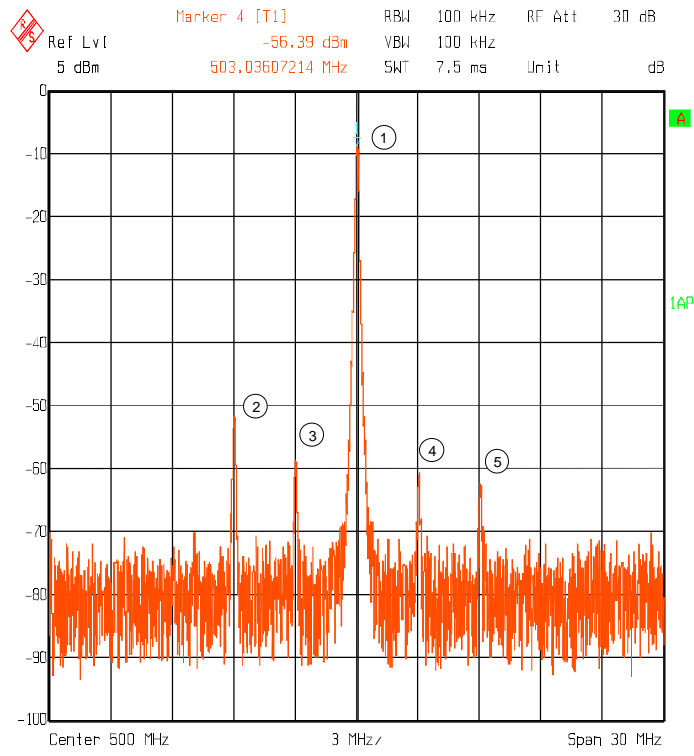

Fig. 7: Output spectrum with 90° power splitter

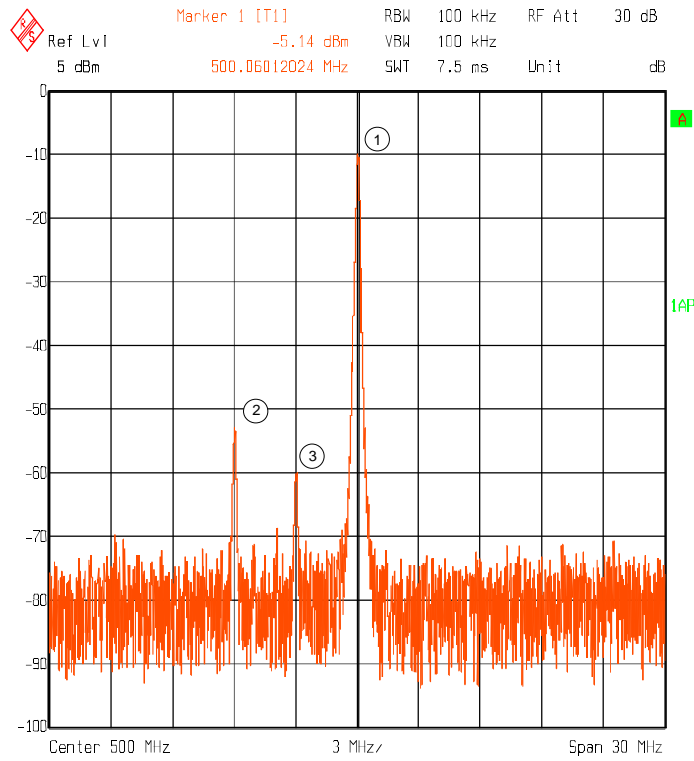

Fig. 8: Output spectrum same as Fig. 4, with additional lowpass filter

Evaluation:

- ☺ Uncomplicated test setup, suppression of second sideband
- ☹ The frequency of the test signal is fixed (range approx. 2 to 5 MHz). The max. fading bandwidth is limited to approx. 2 MHz by the 90° power splitter.

4.3. Use of Additional Mixer and 90° Phase Shifter

If the output frequency of the signal to be faded is in the RF range (> approx. 30 MHz), it is expedient to downconvert the signal to the 3 MHz IF by means of an external mixer. Analogously to 4.2, the 3 MHz IF is then applied to the I-Q inputs of SMIQ via a 90° power splitter.

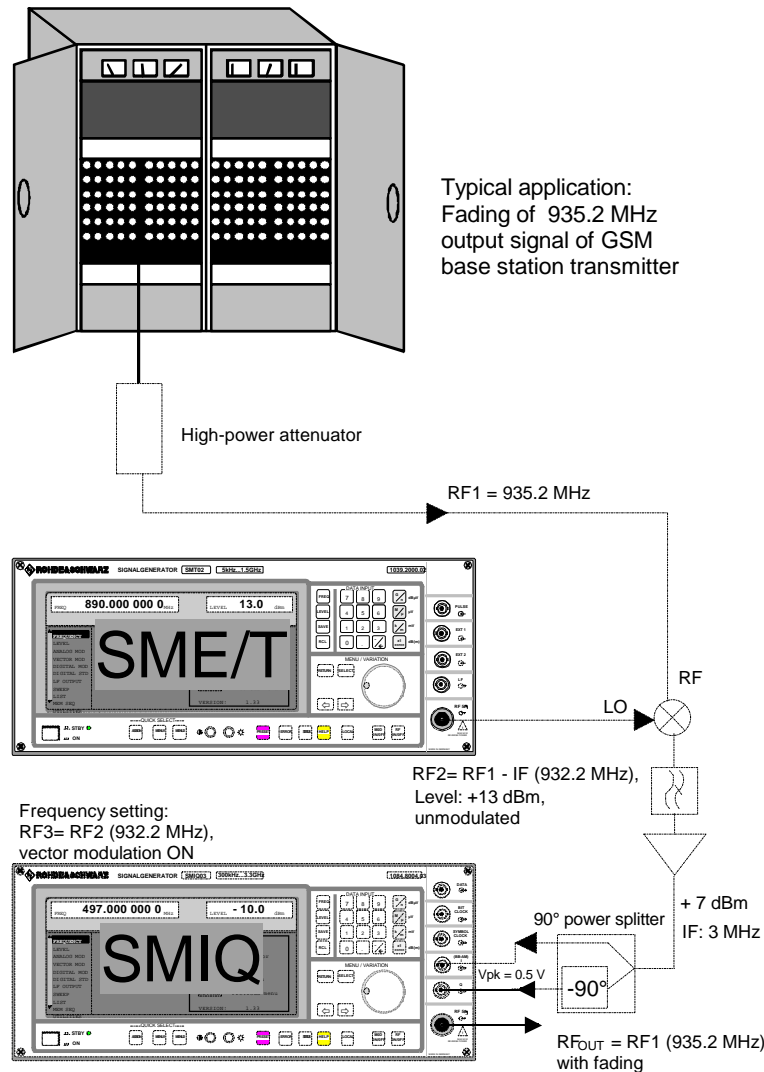

Fig. 9: Fading of RF signal with any type of modulation (example: GSM transmitter signal) by means of additional mixer and 90° power splitter

Settings for fading of any RF signal, eg 935.20 MHz:

Test signal: Frequency: any, eg 935.2 MHz
 Level: -10 dBm,
 Modulation: any

SME/T: (supplies LO signal for the mixer)
 Frequency: frequency of test signal
 - IF (932.2 MHz),
 Level: +13 dBm,
 Modulation: unmodulated

SMIQ: Level: any (max. -5 dBm)
 Frequency: 932.2 MHz
 Vector modulation: ON
 Fading simulator: ON
 Configuration of fading simulator as required for task in hand.

Output spectrum: Same as 4.2, see Figs 7, 8.

Evaluation:

- ☺ Any RF test signal can be faded.
- ☹ Complex test setup (external mixer, amplifier, etc required); additional signal generator needed to furnish LO signal for mixer

4.4. Use of External IQ Demodulator

Maximum fading bandwidth (+5 MHz, -1 dB), eg for special wideband CDMA signals, can be achieved by converting the signal to be faded to the baseband by means of a suitable external IQ demodulator (for example ZAMIQ-895 D from Mini Circuits, suitable for RF signals in the range 868 to 895 MHz). The output signals of the IQ demodulator are to be boosted to the level of +4 dBm required by SMIQ (peak voltage: 500 mV) by means of suitable amplifiers (block diagram of test setup shown in Fig. 10).

The quality of a signal converted to the baseband is decisively influenced by the quality of the IQ demodulator, which will in general be markedly lower than that of the SMIQ modulator. Quality criteria include carrier suppression (DC offset), IQ imbalance, quadrature offset.

Impairment of quality can be avoided (at smaller fading bandwidths) by carrying out conversion to the 3 MHz IF also with the IQ mixer. In this case, however, test setup according to 4.2 or 4.3 would be the simpler one.

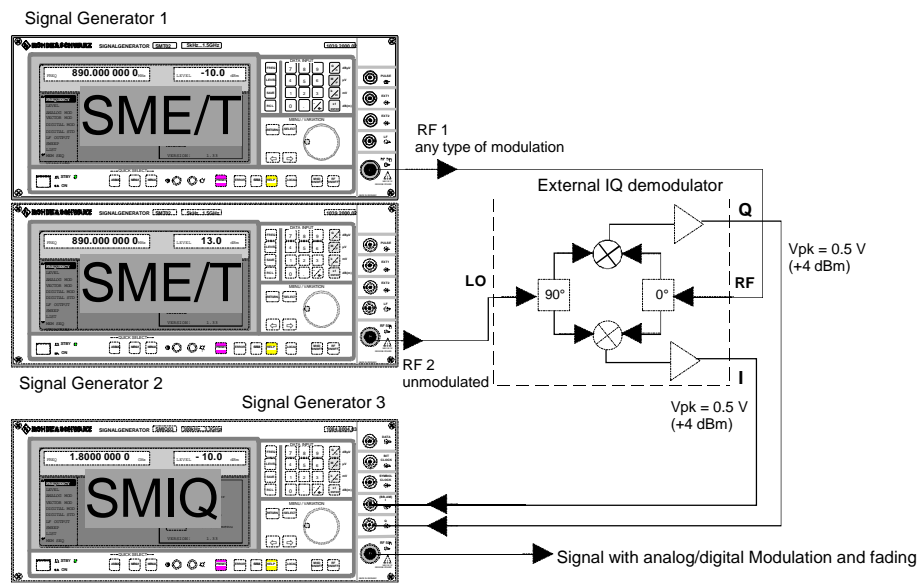

Fig. 10: Test setup for fading a signal with any type of modulation by means of external IQ demodulator

Evaluation:

- ☺ Any RF test signal can be faded by means of a suitable IQ demodulator. Maximum bandwidth through conversion to baseband (IF = 0).
- ☹ Highly complex test setup

5. Summary of Pros and Cons

Procedure to:	Criteria:			
	Complexity of test setup	Distortion of useful signal	Spurious	Possible bandwidth
4.1 with 2nd signal generator	☺ ☺	☺	☹ ☹ (0 dB)	☺ approx. 4 MHz
4.2 with 90° power splitter	☺	☺	☹ (approx. -40 dB)	☹ approx. 2 MHz
4.3 with external mixer	☹	☺	☹ (approx. -40 dB)	☹ approx. 2 MHz
4.4 with external I/Q demodulator	☹	☹	☺ <-50 dB	☺ ☺ approx. 10 MHz

Table 1: Advantages and disadvantages of various procedures using SMIQ as fading simulator for external signals

6. References

- William C. Jakes, Microwave Mobile Communications, IEEE Press
- Operating manual for Vector Signal Generator SMIQ, section 2.9, Fading Simulation

7. Ordering Information

Vector Signal Generator	SMIQ03	1084.8004.03
Fading Simulator	SMIQ-B14	1085.4002.02
Signal Generator	SMT02	1039.2000.02
Signal Generator	SME02	1038.6002.02



ROHDE & SCHWARZ

ROHDE & SCHWARZ GmbH & Co. KG · P.O.B. 80 14 69 · D-81614 München
 Telephone +49 89 4129 -0 · Telefax +49 89 4129 - 3777 · Internet: <http://www.rsd.de>